

1.5A, 2.25MHz Synchronous Step-Down DC/DC Regulator

DESCRIPTION

The EUP3261 is synchronous step-down DC-DC converters optimized for battery powered portable applications. The 2.7V to 5.5V input voltage range makes EUP3261 ideal for powering portable equipment that runs from 1-cell Li-Ion or 3-cell NiMH/NiCD batteries. The device is also suitable to operate from a standard 3.3V or 5V voltage rail.

The EUP3261 operates at 2.25MHz fixed switching frequency allowing the use of small inductors and capacitors to achieve a small solution size. The internal synchronous switch increases efficiency and eliminates the need for an external schottky diode. The EUP3261 has internal soft start and avoids inrush current during startup.

The EUP3261 operates in PFM/PWM mode which provides high efficiency at light loads. The EUP3261 is available in SOT23-5 package.

FEATURES

- High Efficiency Up to 95%
- 2.25MHz Constant Switching Frequency
- 1.5A Available Load Current
- 30 μ A Typical Quiescent Current
- 2.7V to 5.5V Input Voltage Range
- Adjustable Output Voltage as Low as 0.6V
- No Schottky Diode Required
- Short Circuit and Thermal Protection
- Internal Soft Start Function
- Available in SOT23-5 Packages
- RoHS Compliant and 100% Lead(Pb)-Free Halogen-Free

APPLICATIONS

- SSD Module
- Smart Phones
- Tablet PC
- Portable Media Players
- μ C/ μ P, FPGA and DSP Power
- Plug-in DC/DC Modules for Routers and Switchers

Typical Application Circuit

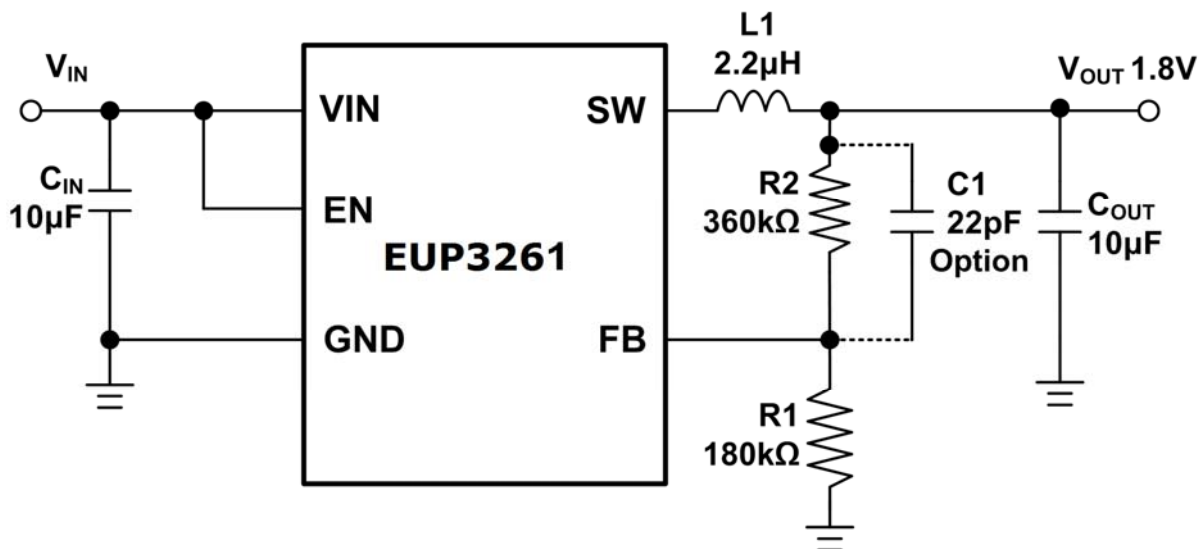

Figure 1.