

1A Linear Charger with 5V/0.4A Synchronous Boost Converter

DESCRIPTION

The EUP8065 is a fully integrated power management unit specifically designed for TWS Bluetooth Battery Charger, Power Bank and Backup Battery Charger applications. It consists of a high efficiency synchronous step-up boost converter and a linear battery charger.

The boost can provide up to 400mA output current at 5V from a Li-Ion battery input voltage, the charger can charge up to 1A current for the Battery. Thermal feedback regulates the charge current to limit the die temperature during high power operation or high ambient temperature. The charge float voltage is fixed at 4.2V and the charge current can be programmed externally with a single resistor. The EUP8065 automatically terminates the charge cycle when the charge current drops to 1/10th the programmed value after the final float voltage is reached. Other features include charge current monitor, under voltage lockout, automatic recharge and a status pin to indicate charge termination and the presence of an input voltage.

The EUP8065 is available in SOP-8(EP) package.

FEATURES

- Up to 1A Programmable Charging Current
- Input Voltage up to 24V
- CC/CV Charge Mode
- Preset 4.2V Charge Float Voltage with 1% Accuracy
- Automatic Recharge
- Charge Status Output pin
- C/10 Charge Termination
- Up to 95% Boost Efficiency
- 1.4MHz Fixed Switching Frequency for Boost
- 1.5 μ A No load IQ for Boost
- 5V/0.4A for the Boost Output
- Thermal Shutdown
- SOP-8(EP) Package

APPLICATIONS

- Portable Power Bank
- TWS Bluetooth Battery Charger
- Portable Media Players
- Tablet PC

Typical Application Circuit

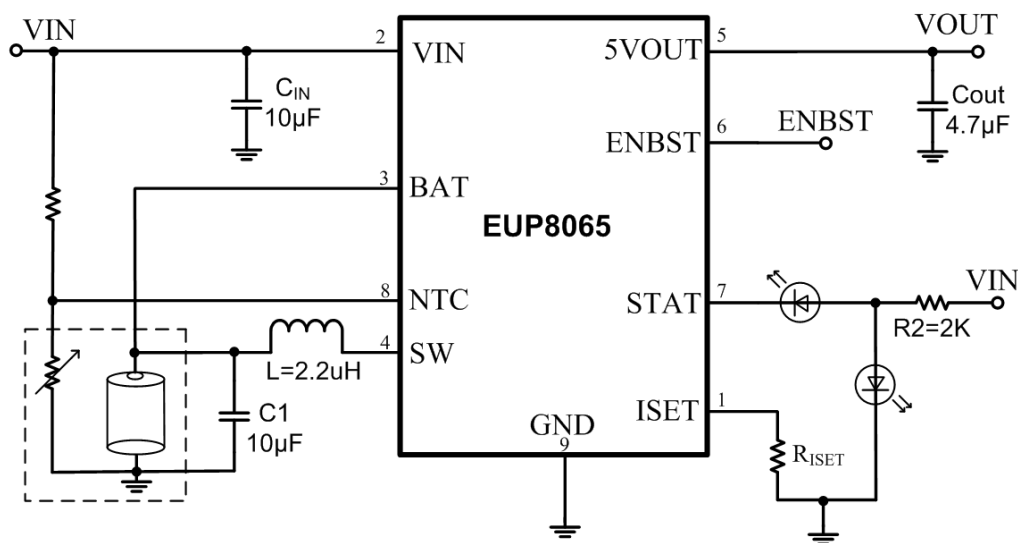

Figure 1. Application Circuit